

Know the Electricity Act 2003

This section of Prayas web-site is an effort to enhance public awareness about evolving power sector policy in India. Electricity Act 2003 (called E-Act), enacted in June 2003 marks a watershed in the Indian power sector, with fundamental and far-reaching impacts. In many ways, the importance, complexity and the resultant flux of E-Act can be compared to the Orissa Electricity reform Act, 1996. E-Act involves fundamental changes in the conceptual and legal foundation, distribution of authorities, and functional procedures of the sector. The Act envisages evolution of various policies, rules and regulations to implement the new structure. No wonder, the power sector in India is undergoing massive changes at a very high pace after promulgation of the E-Act.

This section attempts to give a comprehensive overview of the E-Act and the related policy initiatives. Since many developments are in progress now, there is a section called Alerts, which lists important happenings. Where required, reference to the relevant clause of E-Act is given in square brackets. Links, to related documents may be useful for those who wish to study further and can be accessed at our website www.prayaspune.org. Important links list the website addresses of key organisations and the Glossary gives the explanation of key terms used. This webpage is organised in 12 sections. It is hoped that these web-pages would be helpful to consumer groups, NGOs, journalists, and analysts to improve their appreciation of E-Act and related policies. Please send your comments to prayasenergy@vsnl.net.

Table of Contents

1. Background

- 1.1 Major milestones in India power reforms
- 1.2 Electricity Act – process, importance
- 1.3 Summary of E-Act
- 1.4 Overview of Impact
- 1.5 Schematic Overview of Changes

2. Generation

3. Transmission

- 3.1 Load Dispatch
- 3.2 Open Access

4. Distribution

- 4.1 Ownership
- 4.2 Allowing more than one distribution license
- 4.3 Rural distribution and household electrification
- 4.4 Other issues

5. Regulation

- 5.1 Introduction
- 5.2 Regulatory Commissions
- 5.3 Appellate Tribunal

6. Power Trading

7. Consumer Issues

- 7.1 Grievance redressal
- 7.2 Theft

8. Tariff

9. Institutions and Policy

- 9.1 Increasing role of Central Government
- 9.2 Electricity: from a development input to a commodity
- 9.3 Reducing role of CEA and centralised planning
- 9.4 End of the road for SEBs

10. Major policy initiatives

11. Alerts

12. Annexure

Important Links
Regulatory Commissions
Glossary of terms

Know the Electricity Act 2003 (E Act 2003 of India)

1. Background

Electricity Act 2003 is said to be the culmination of the power reforms that started in early 1990s. A brief run through of the major events in India that led to E-Act will be useful.

1.1 Major milestones in India power reforms

| Reforms: Major milestones | |
|---------------------------|----------------------------------------------------------|
| Year | Milestone |
| 1991 | IPP Process |
| 1996 | Orissa Reform Act |
| 1998 | Central Electricity Regulatory Commissions Act |
| 1999 | RCs in many States, Distribution Privatisation in Orissa |
| 2002 | Privatisation of Distribution in Delhi |
| 2003 | Electricity Act |

In early 1990s, reforms in the Indian power sector started with the entry of private players into power generation. The Central and State governments encouraged national and multinational companies to set up what is called Independent Power Producer (IPP) projects. Enron in Maharashtra, GVK & Spectrum in AP, Essar in Gujarat etc are examples. The initial response was quite good, but ultimately only few plants were set up and many have been ridden by controversies. Now it is clear that the IPP process not only resulted in high cost projects but also failed to solve the problem of generation capacity shortage. Despite a decade of policy focus, in FY 2002 the IPPs contributed barely 3% of national generation (15,000 MU). Where as, the improved plant performance during this decade contributed 3.5 times more than IPPs!

At the same time, Orissa government with active support from the WB decided to change the structure of its power sector. This reform initiative called the 'Orissa model' involved unbundling and privatisation of State Electricity Boards. A new institution called Regulatory Commission was formed to decide tariff and regulate the sector. This experiment was started in Orissa with passage of the Orissa Reforms act in 1996. Many other states followed suit. But only Orissa and Delhi actually privatised the electricity distribution business in 1999 and 2002 respectively. [[See Prayas Power Reforms Update reports covering all-India, and the states of Orissa, AP, UP and Maharashtra](#)]

The Electricity Regulatory Commissions Act was passed in 1998 by GoI to enable states to create Regulatory Commissions without passage of state Act. In the next two years Central and several state regulatory commissions were formed under this Act and in some cases, under separate State Acts. [See Prayas reports (a) [On Regulatory Commissions \(1998\)](#) and (b) [Survey of functioning of 12 electricity commissions in India \(2003\)](#).] After the IPP fiasco many reform initiatives in the Distribution sector were started by the central government. Central government also started working on a comprehensive legislation to replace all the existing ones. This effort led to the Electricity Act.

1.2 Electricity Act – process, importance

In August 2001, the central government introduced a bill, 'The Electricity Bill 2001'. This bill underwent many versions, was debated in the budget session of parliament in 2003 and was passed by both the houses. This was enacted as Electricity Act 2003, on June 10, 2003. This Act provided for increased competition in the sector by facilitating open access in transmission and distribution (open access is a permission to use the power lines), power trading and also allowing setting up of captive power plants without any restriction. E-Act would override all the existing acts governing the power sector and State reform Acts passed earlier that contradict the E Act would have to be suitably amended so that E Act will prevail.

The story of Electricity Bill starts in the year 2000 when the then central minister for power, Mr. Kumaramangalam initiated the drafting of a new comprehensive bill to update legislation in the power sector with the reform spirit. The consultant, the NCAER produced many versions of the draft, and for quite a while, it was called Electricity Bill 2001, since it was introduced in the Parliament in August 2001. Mr. Kumaramangalam passed away in 2000, Mr. Suresh Prabhu replaced him and later Mr. Anant Geete took over as Power minister in August 2002. There was a Parliamentary committee to look into the bill, which suggested some changes. The Lok Sabha passed this bill, now called Electricity Bill 2003, in early April 2003 without any amendments. Many amendments were suggested in the Rajyasabha, but they were kept pending and the bill was passed there too in late April. After Presidential assent, this Bill was enacted as Electricity Act 2003 on June 10, 2003. Enforcement of section 121 was kept in abeyance. Amendments to sections 14, 42, 121, 135, 139, 140 and 146 were passed in the Rajyasabha on December 8 and Lok Sabha on December 18, 2003. These amendments are related to the open access, appellate tribunal and theft. Timeframe for introducing distribution open access was defined as 5 years and overriding importance of Appellate tribunal was reduced by these amendments.

1.3 Summary of the Electricity Act

The Electricity Act 2003 (E-Act 2003) is a 100 odd page document with 185 sections covered in 18 parts. Till now, the Electricity Supply industry in India was governed by three enactments: the Indian Electricity Act 1910, the Electricity (Supply) Act 1948 and the Electricity Regulatory Commissions Act 1998. The 1910 Act gave the basic framework for the industry. It envisaged growth through private licensees and provided for licensees to supply a specified area. The 1948 Act mandated the creation of State Electricity Boards (SEBs) with the responsibility of managing electricity supply in the State. The 1998 Act created the Central Regulatory Commission and gave the legal framework for creating State Regulatory Commissions. Electricity Act 2003 replaces these laws and is said to harmonise the provisions of these through a new comprehensive legislation meeting the reform related issues like trading, competition etc. Prior to 2003, state Acts enabling power sector reforms had been passed in 8 States - Orissa (1996), Haryana (1997), Andhra Pradesh (1998), Uttar Pradesh (1999), Karnataka (1999), Rajasthan (1999), Delhi (2000) and Madhya Pradesh (2000). Provisions in these state Acts that are inconsistent with the E Act will be modified so that E Act provisions prevail.

The main features of the E-Act are:

1. Generation delicensed: Thermal generation does not need clearance from CEA. Only large or inter-state Hydel projects need this.
2. Setting up Captive generation does not need permission. Captive generation can be set up by a group or society to meet their needs. The captive plants can be located off-site (far from the consumption point)
3. Transmission utility at the central level will continue to hold responsibility of co-ordinating planning of the transmission network. These utilities or the State governments would look after load dispatch (scheduling of plants, maintenance etc).
4. Private companies can build Transmission lines for captive use or for common use

5. Open Access: Any generating station will get access to the transmission system at a fee, subject to capacity availability. They will have to pay a fee to the transmission utility (called wheeling charge) and charges for load dispatch centre. Bulk consumers including DISCOMS can take advantage of Open access by purchasing the wheeled power. Large consumers will have to pay a surcharge to cover cross subsidy, except in case of the captive generating stations. The State Regulatory Commission may permit Open access in distribution in phases and can levy a surcharge on users buying power through open access. This will be utilised to cover cross subsidy in that area.
6. Distribution licensees are free to undertake generation and generation companies are free to undertake distribution license. The commission can allow multiple licenses in the area of a distribution licensee.
7. For rural and remote areas, stand alone systems for generation and distribution are allowed. Distribution managed through Panchayats, User associations, Co-operatives or Franchises would also be permitted without needing license (in state government notified areas).
8. Power Trading is being recognised as an activity that can be taken up after authorisation of RCs. The RCs would issue licence and fix ceilings on trading margins. Distribution licensees and state governments do not require license to carry out trading.
9. After Open access is allowed, consumer can enter into direct commercial relationship with a generating company or Trader. In such a case, the price of power will not be regulated, but the transmission charges (called wheeling charges) and surcharge would be.
10. State governments can un-bundle SEBs and create companies. At the minimum the transmission activity needs to be separated from SEB. All states should have Regulatory Commissions.
11. An Appellate tribunal will be created at the Centre for disposal of appeals against decisions of CERC and SERCs.
12. Strict provisions to deal with power theft.
13. Tariff: Tariff would be along commercial principles to encourage competition and efficiency. Multi year tariff formulation is suggested with gradual elimination of subsidises. Metering to be 100% in a few years time. Time of the Day tariff to be introduced in a phased manner.
14. Central government would bring out National Electricity Policy, Tariff Policy, National policy on standalone systems for rural areas and a National policy on electrification & local distribution in rural areas. CEA shall prepare National Electricity Plan

1.4 Overview of Impact

It is early to comment of the impacts of E Act, as they depend on the policies, which are yet to be finalised. Some key aspects of the possible impact of E-Act in the coming decade are discussed below:

1. Entry of more players (mostly private, some public) into generation, transmission, trading and distribution.
2. Increase of captive generation, especially group captives, set up by group of industries to meet their power needs. Many bulk consumers would quit state owned distribution utilities.
3. Many contracts between generators and bulk consumers (private and public – e.g. NTPC & Railway, private generation company & large industry etc), which would be finalised and operated without public scrutiny.
4. Tariff will change slowly to reflect the cost to serve and cross subsidy will get reduced and finally disappear. State government may give subsidy in advance if it wants to lower the tariff for some consumers.
5. Increased role of Central government in policy formulation

6. End of vertically integrated Electricity Boards.
7. Power sector becomes more complex with entry of many more actors and contracts. Group captive, private distribution companies, transmission licensees and power traders are some new actors. With open access, TOD tariff, many supplier- trader - consumer contracts and many dispersed systems, planning, regulating and operation of the system becomes more complex.
8. Financial deterioration of many state owned utilities – as they will increasingly serve only small and rural consumers.
9. Segmentation of the society into four parts. These are:
 - A. Large consumers: They would be allowed to access new (low cost) generation or put up their own captive plants. These consumers would see a major reduction in their tariff and be allowed to shrug off or reduce burden of the historical costs (stranded costs).
 - B. Urban small consumers: Private players may be interested in taking up Distribution for these areas. These consumers may remain under regulated monopoly for quite some time to come. The private companies may see these urban consumers as captive consumers not just for distribution but also for their proposed generation plants (unless RCs force competitive bidding for new power plants these will again become vertically integrated monopolies).
 - C. The Rural small consumers: These consumers would also be under regulated monopoly, which is likely to be under public ownership. These consumers are the largest in number and would be taking the largest brunt of tariff increase.
 - D. Rural Un-connected Population: The last section is the prospective consumers. The actions for these consumers under other policies are yet evolving. There is urgency to clearly spell out what will be done for these consumers, and is expected through the Rural Electrification policies of MoP.

To discuss the impact of E Act, we have looked at different functional aspects of the sector. This include – Generation, Transmission, Distribution, Regulation, Trading, Theft, Consumer grievance, Tariff and Institutions & Policy. Each of these is seen with reference to the status before E-Act and possible impact of E-Act.

1.5 Schematic Overview of Changes

1. Integrated Utility

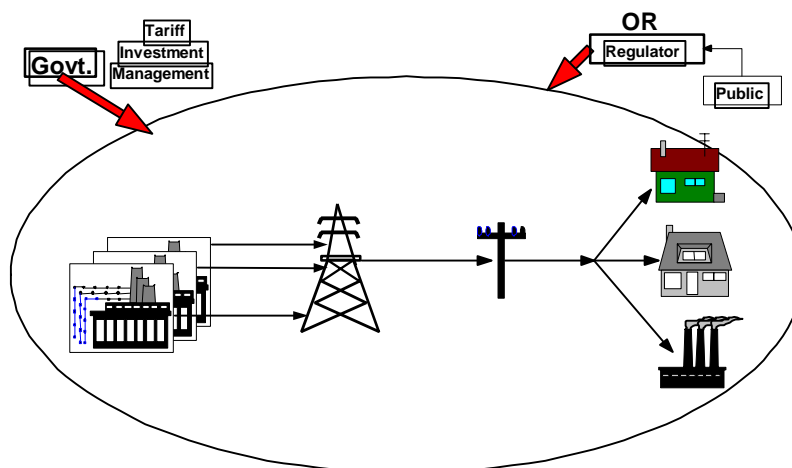

2. Single Buyer Model (Orissa)

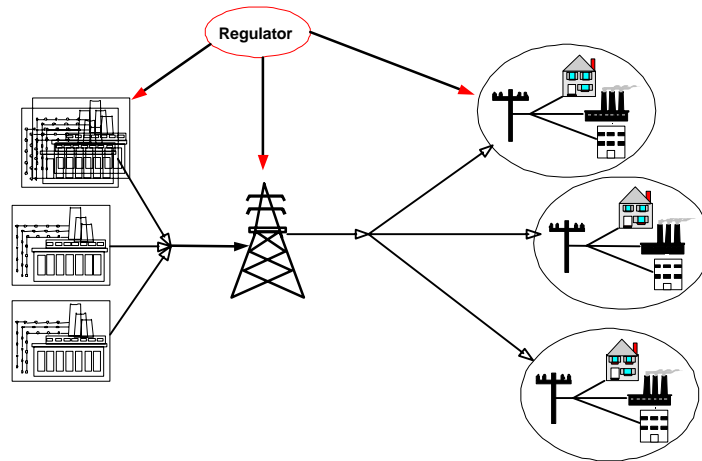

3. Bulk Competition – E-Act Model

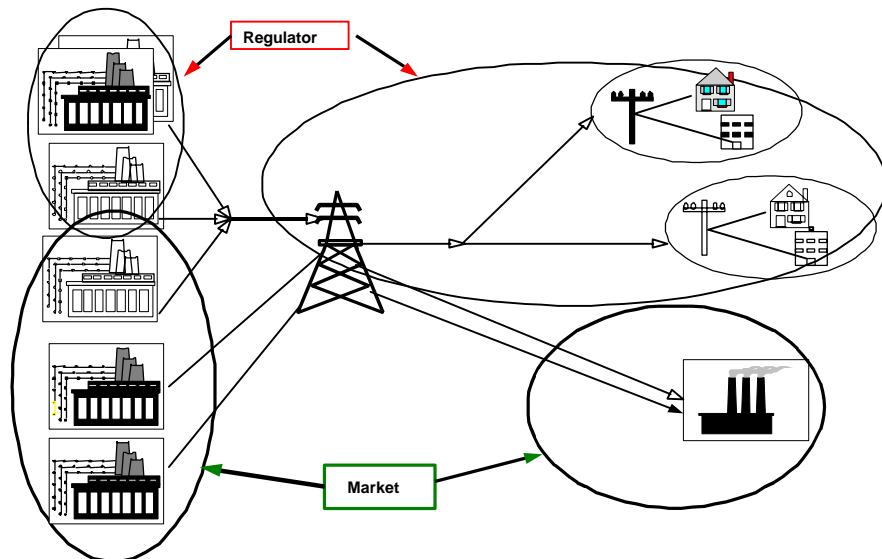

2. Generation

As of June 2005, the government owned 89% of the generating capacity in the country. Around 60% was owned by State utilities and 30% by Central utilities. Private companies and IPPs formed the remaining 11% of the total capacity. Capacity additions by State utilities and IPPs had slowed down, while Central utilities have ambitious plans for capacity addition. Many big industries (especially the continues process ones) have captive power plants, which supply the essential power requirement during grid supply failure. This captive capacity is estimated to be around 20,000 MW.

MoP has prepared an ambitious plan of adding 1,00,000 MW during the 10th and 11th plan, i.e. from 2002 to 2012. (Incidentally, this works out to about 430 MW of capacity addition every fortnight!). For the 10th plan the capacity addition plan is about 45,000 MW, central, state and private sectors share is expected to be 51%, 16%, and 25% respectively. About 7% is expected to come from renewable sources and 2% from Tala project in Bhutan (Ref. Capacity Addition

Program, Mission 2012, MoP). The MoP has undertaken a Hydro Power initiative, launched by the Prime Minister in 2003, under which a capacity of 50,000 MW is to be added.

Till the E-Act, Techno-Economic clearance by CEA was essential to set up generating plant. This was to ensure optimisation of capacity additions, correctness of technology and fairness of costs. From 1990s, requirement of CEA clearance was getting slowly relaxed, with smaller projects not requiring this.

Sections 7 to 11 of the E-Act cover different provisions in Generation. Generation has been de-licensed in the E-Act. While Hydro stations require CEA clearance, thermal and gas stations do not require this [7,8]. Definition of captive generation has been broadened. "Captive Generating plant means a power plant set up by any person to generate electricity primarily for his own use and includes a power plant set up by any co-operative society or association of persons for generating electricity primarily for use of members of such co-operative society or association" [Part I, Definitions]. Note that the word 'primarily' is not defined anywhere. Also note that by this definition, a group of industries can set up a big generating station near a mine for their group's use and sell excess power. In June 2005, MoP has issued a notification on Electricity Rules, which clarifies captive generation. As per this, captive users should hold more than 26% share in the plant and consume more than 51% of electricity generated.

It is expected that there would be increase in private generation companies and captive plants. Some private companies, like Tata Power and Reliance Energy have already announced plans of setting up large power plants to cater to large industrial consumers. Quantum of such plants, also called "Merchant plants", is likely to grow in the coming decade. It is another related matter that the increased availability of gas, proposed gas pipelines and possibility of LNG and coal import on both coasts has widened the choice of fuel and technology for generation. The likely economics of generation favours imported coal for coastal regions, followed by mine-mouth coal and gas. In case of industrial co-generation the gas is invariably the best option.

In many ways, E-Act dilutes the role of centralised planning. There is a danger that the small inefficient captive plants may be set up and country-wide optimization of generation and transmission may be affected. It may be noted that in some countries like the UK, central strategic planning is staging a come back after a decade of de-regulation.

3. Transmission

Sections 25 to 41 of E-Act cover different aspects of Transmission. Transmission function in the States is currently being handled by unbundled SEBs or state owned Transmission Corporations. At the national level, POWERGRID is the inter-state, inter regional transmission utility. Transmission facilities of one utility are being used by another under bi-lateral contracts (for example for transporting power from Farakka in West Bengal to Andhra Pradesh). Such sharing will now be legally mandatory, under open access (see later). Entry of private players into transmission sector (i.e. ownership) was being planned even before E-Act. E-Act permits private transmission licensees, or captive transmission lines by private companies.

3.1 Load Dispatch

Transmission licensees are responsible for grid operation and planning. Central Transmission Utility (CTU, which the GoI is to notify and is expected to be the POWERGRID corporation) coordinates inter-state transmission. It cannot undertake the business of generation and power trading. Other Transmission licensees (State or Private) cannot undertake power trading.

E-Act outlines the role of Load Dispatch Centres at National (NLDC), Regional (RLDCs) and State (SLDC) levels [26,27,28,29]. One NLDC, five RLDCs for North, East, North-East, South and West regional grids and state wise SLDCs are expected to be set up. LDCs are expected to coordinate grid operation and it is mandatory for licensees and generation companies to follow their instructions. The SLDCs are expected to follow the instructions of the respective RLDCs. These LDCs would be operated by a government company, authority or corporation notified by the government (GoI for NLDC and RLDC; State government for SLDC). Currently the SEB/TRANSCO operates the SLDCs and POWERGRID operates the RLDCs. RLDC cannot undertake the business of generation or trading. NLDC and SLDC cannot undertake trading. Interestingly, nothing is mentioned about generation, presumably to allow possibility of LDCs owning peaking plants for grid stability.

3.2 Open Access

After the E-Act, Transmission licensees have to provide 'non discriminatory open access' for transmission of power. This means that if there is spare capacity available, transmission lines should be made available to whoever demands it for transferring power.

Transmission open access is relevant for transporting (technically called 'wheeling') of power across states and across regions. Even today, power generated by Central generating Stations (CGS) is wheeled across states and regions by the transmission system of Powergrid. These are based on mutually agreed contracts. E-Act brings in non-discriminatory open access, which means that a transmission utility cannot refuse to wheel power unless it has capacity limitations. Another fallout of E-Act is the entry of many more players to wheel power - this could be private generation companies, captive units etc. who wish to sell power to DISCOMs or bulk consumers located at a distance (even at another corner of the country). Power traders, who buy/sell power would be another key actor in the process. Relevance of issues of open access is different for inter-state and intra-state (within the same state) transfer. As mentioned before, provisions for intra-state open access are to be formulated by the respective State RCs.

CERC prepared a discussion paper on Open access for interstate transmission in August 2003. Comments were invited, public hearing held in September and a draft regulation issued in December 2003. (see [Prayas comments](#) in October 2003 on Draft Paper). Subsequently, CERC has issued the final order and regulation on Open Access in January 2004, which are available at CERC website (www.cercind.org). The main features of this regulation are given below.

- Methodology & Procedure is announced for seeking open access in inter-State transmission.
- Existing Regional Postage Stamp pricing method to be applied for inter-state transmission pricing.
- Discoms, Traders, IPPs, captive Plants can immediately avail inter-State open access on Inter-state lines (if they are directly connected to POWERGRID substations).
- Two categories of open access consumers - short term (less than one year) and long term (25 years or more)
- Nodal Agency for short-term consumers will be the RLDC within which the point of drawal is located.
- CTU will be the nodal agency for long-term consumers.
- Long-term consumers to be treated at par with original beneficiaries of the CTU network.
- Short-term consumers will be curtailed first in case of transmission constraint.
- Mismatches in the energy drawals by the open access consumers to be billed as per the existing frequency linked unscheduled interchange charges (UIC) under Availability Based Tariff (ABT).
- CERC recommends adoption of ABT at the State level. Right now, ABT is implemented at the regional level for 5 regions of the country

Open access on the state level transmission and distribution lines is to be decided by the state RC. Many states have issued orders for intra-state open access, suggesting introduction in phases, with the big consumers (say with connected load greater than 5 MW) getting the facility first and those with load greater than 1 MW latest by December 2008, the end of the 5 year deadline.

With the provision of open access, transmission network will become like a toll highway, which can be used by any one by paying a toll. It is likely that power traders, private distribution companies and private generators use this facility to reduce operating costs. The monitoring agencies like RLDC, and RCs will have to equip themselves to ensure proper energy accounting and monitoring systems. Unscrupulous generators and consumers can exploit any weaknesses that remain in energy accounting.

4. Distribution

E-Act brings in a few major changes in the distribution sector.

- a. Allowing more than one licensee to operate in the same area
- b. Open access is to be introduced by the State RCs in a time bound manner (consumers with load greater than 1 MW have to be given open access in less than 5 years)
- c. Plan to allow stand-alone generation/distribution systems – without a need for license. Local distribution system in rural areas can be managed by panchayats, user associations, co-operative societies, non-governmental organisations or franchises [4,5]. In some areas this may not need License [14]
- d. The distribution company can appoint NGO, co-operative or even private person as a franchisee to act on its behalf. This can increase the contracting out of retail sales and bill collection activity.

4.1 Ownership

After unbundling of SEBs, in many states, distribution is being handled by 3 or 4 state owned corporations. Some major states are yet to declare their plans for unbundling and corporatisation – which the E Act expects them to do by June 2004. State governments would not need any legal change to privatize these un-bundled companies. Private distribution companies were an exception in India but are increasing in number. Mumbai, Calcutta, Ahmedabad, Surat and NOIDA are exceptions with the distribution being managed by private companies for many years. [for comparative performance of these old private distribution companies see Prayas Report (2003)]. Distribution in Orissa and Delhi were privatised in 1999 and 2002 respectively. Tata Power (manages part of Mumbai and Delhi), Reliance Energy (manages suburbs of Mumbai, 3 companies in Orissa, 2 in Delhi), RPG Group (Calcutta, NOIDA) and Torrent (Ahmedabad and Surat) are few big private players in power distribution today. Except in Mumbai, there has never been more than one distribution company active in the same geographical area. Even in Mumbai, where Tata and Reliance (formerly BSES) operate in the same area, the overlap has been limited to large consumers or only for part of area otherwise their operation has been more or less mutually exclusive.

4.2 Allowing more than one distribution Licensee

Permitting more than one licensee in same geographical area is a crucial policy change [14]. In such cases, the RC needs to grant license and would only fix maximum ceiling of retail tariff [62]. This provision may be used for ‘cherry picking’ where private distribution companies would set up parallel distribution systems in selected urban/industrial areas. Possibility of predatory pricing exists; i.e. players with money power offering low tariffs at entry stage (as only ceiling on tariff is specified) to capture market. This is still a debated issue; the REL and TPC have applied for 2nd distribution license for several areas in Maharashtra. The decision of MERC is still

awaited on this. See Prayas submission to MERC on this issue. If a minimum area, required consumer mix, and some social obligations related to access are not decided before granting multiple licenses then the resultant cherry picking may have serious adverse impact on the rural areas.

4.3 Rural distribution and household electrification

Issues related to rural electrification are many. Under Section 4 and 5 of the Act, the Ministry of Power (MoP) is entrusted with the task of evolving various policies, including the National Electricity Policy, the Tariff Policy and the Rural Electrification policies.

In the month of November 2003, the GoI came out with a Discussion Paper on National Rural Electrification (RE) Policies, which sheds light on the planned process as well as substantive issues involved in framing the RE policies. The discussion paper refers to the two policies mentioned in the Act – i.e. national policy on stand-alone systems for rural areas (Section 4) and national policy for rural electrification and for bulk purchase of power and management of local distribution in rural areas through local government institutions, NGOs, or franchisees (Section 5). These provisions are major deviations from the past.

In the budget for FY 2005-06, government has allotted Rs. 11,000 crores for rural electrification. 790 lakh households and 1.25 lakh villages will be electrified in the next five years. This fund will be utilised under the new scheme “Rajiv Gandhi Vidyutikaran Yojana”, launched by the Prime Minister in May 05. The Rajiv Gandhi yojana will be launched in 10 states. Rural Electrification Corporation (REC), a non-banking finance company under the power ministry, would be the implementing agency. Under the scheme, a 33/11 kV substation will be built in each block and at least one distribution transformer in each village. 90% capital subsidy is given and 10% as soft loans at 5% interest. 100% subsidy is provided for electricity connections to Below Poverty Line homes.

According to the Census 2001, 40% of population, i.e. nearly 56% of rural population do not have electricity, though 87 % of villages are electrified. Under the Mission 2012, the GoI has set itself a goal of ‘Power to All by 2012’ - electrification of all villages by 2007 and all households by 2012. This would need electrification of 8 crore rural houses in the coming decade (which would cover nearly half of the country’s rural population). It means electrification of nearly 1,000 households per hour! This will be supported by massive central government subsidy (of the order of thousands of Crore Rupees per year). The ministry envisages three approaches for rural electrification: on-grid, off-grid, and hybrid systems. Consultative process involving presentations, workshops etc are planned before finalising the policy.

4.4 Other Issues

- E-Act suggests that no one should be supplied electricity without metering by 2005 [55]. But this seems an impossible task. Today large shares of already metered consumers are not billed as per consumption! This includes large share of even high value LT commercial consumers.
- There are clauses that mandate the utility to give connection on request and abide by performance standards among other issues. This will establish consumer rights.
- Distribution licensees are free to take up generation [Statement of Objects, point 4 – v]. But it is in consumer interest to force all DISCOMs to procure additional power through competitive bidding rather than simply allowing them to build their own plants.

5. Regulation

5.1 Introduction

Electricity Regulatory Commission (ERC) was first set up in Orissa in 1996. Subsequently 27 more states have set up SERCs (2005). CERC handles issues of central utilities and those having inter-state nature. Procedure for selection of members, conduct of business rules and monitoring practices are laid down in sections 76 to 109 of the E Act, which are largely similar to the ERC Act 1998. E-Act formulates a new body, called the Appellate tribunal to deal with appeals against the decisions of the RCs [Sections 110-125].

5.2 Regulatory Commissions

E-Act requires that all states set up RCs within 6 months of notification of the Act, i.e. by December 2003 [89]. Small states/Union territories may set up joint commissions [83]. CERC will have 4 members and an Ex-officio member (CEA chairperson) [76], the SERCs not more than 3 members [82].

Appointment of Members: To appoint members for all commissions, government (central for CERC and state for SERC) will constitute a selection committee [78, 85]. Central committee will have Member-Energy of the Planning commission as chairperson and Secretary-Legal, Chairperson – public enterprise selection board, head- a public finance institution (nominated), head- research/technical/management institution (nominated) and secretary-power as members. For the SERCs, a person who has been a judge of the High court will chair selection committee. The Chief secretary and the Chairperson of CEA or CERC are the other members of the committee. The selection committee would suggest two names for every vacancy referred to it and the government would choose one. Selection committee would also suggest name of the Chairperson for the commission. The government has a dominant role in selection of members and the past records show that an overwhelming majority of ex-government officials are selected for the posts.

Unfortunately, suggestions for public accountability during the selection process have not been accepted in the Act. These suggestions include, making public the report of the selection committee, inviting public comments on the names being considered by the selection committee etc.

The commissioners will have a term of 5 years, and reappointment is not allowed on the same post in the same commission (allowed if member becomes a chairman or in another commission). Central or State government can remove members of the relevant commission under specific conditions. Some of these require an inquiry and order by the Appellate tribunal [90].

Advisory Committee: Advisory Committees are to be set up for CERC and SERCs. These would have representatives from different stakeholders of the sector [80, 81, 87, 88] and RCs can seek advice from these committees.

Authority: RCs will determine tariff, regulate electricity purchase, issue license, and advise government [79, 86, 178, 181]. The RCs have tremendous authority over licensees – including deciding their standards of performance, consumer grievance forums, etc. In case of non-performance or indiscipline by licensees, the RC can fine utilities, officers and even force company to sell the assets / revoke the license. All proceedings before the commission shall be deemed to be judicial proceedings and the commission deemed to be a civil court. It will have powers of entry and seizure of documents [95, 96]. There will be a separate fund to meet the expenses of the commission and every commission shall prepare an annual report. The central or state governments can give directions to the respective commission on policy matters, which RCs have to follow [107-109]. The RCs will have to accept the tariff if it is arrived through

competitive bidding, be it a generation cost or cost of transmission lines. The RCs will play no role in direct transactions between generator, trader, and consumer (utilizing power through open access). The RCs may limit profitability of traders (margins) and fix minimum and maximum generation tariff for a period of one year if it finds the generation cost to be un-reasonable [62(1) a].

The existing RCs will continue to function and those states, which do not have one, shall set it up. The conduct of business rules (CBR) of the RCs will change after the E-Act and the RCs are in the process of changing them.

5.3 Appellate Tribunal

Appellate Tribunal for Electricity (ATE) is a new entity created by the E-Act. Sections 110-125 cover the ATE. Appeals on decisions of any RC can be filed with the ATE. ATE will have a Chairperson and 3 members. There would be at least one judicial and one technical member. The chairperson shall be (or has been) a judge of the Supreme Court or chief justice of a High Court. Members shall be (or has been) judge of High Court, or secretary at the central government in economics/ infrastructure sector or an experienced person in power/ regulation/ economics/ commerce/ law/ management. The chairperson of ATE shall be appointed by the central government in consultation with the Chief Justice of the Supreme Court. Members shall be appointed by the Central government on recommendation of the same selection committee formed for CERC [section 78]. The term of the members on ATE would be three years, and members would be eligible for reappointment once. The members would retire at the age of sixty-five and chairperson at seventy.

ATE shall be deemed to be a civil court. The benches of ATE will ordinarily sit in Delhi and other places as decided. The chairperson of the ATE would constitute benches with two or more members. All benches will have at least one judicial and one technical member.

The original E Act 2003 section 121 said: 'The Chairperson of ATE shall exercise general power of superintendence and control over the appropriate commission' [121]. There was criticism about this clause since it reduces the independence of State RCs. This section was not enacted in June 2003 and was subsequently amended in December 2003 to say that ATE may issue orders, instructions or directions to RCs for performance of its statutory functions. This waters down the power of ATE over RCs to some extent.

There was lot of delay in the appointment of the ATE and finally in May 2005, a 4-member ATE has been set up. . The Chairperson of the tribunal is Shri Justice Anil Dev Singh, retired Chief Justice of the Rajasthan High Court. The other members are Justice E. Padmanabhan (retired Judge of the Chennai High Court), Shri H.L Bajaj (ex-Chairman, CEA) and Shri A.A. Khan (retd. CMD of PFC).

6. Power Trading

Power trading between utilities was limited till recently to bi-lateral contracts between them. Power Trading Corporation (PTC) was set up as a central corporation in 1999 to promote inter-state trading. Some states or utilities with excess power (like Orissa), or those unable to utilize their share of central pool have been trading power. Some states have also been engaging marketing agencies to identify attractive bi-lateral contracts.

Electricity Act recognises trading as a separate activity [52]. Trading can be inter-state or intra-state and the appropriate RC is to fix the eligibility criteria for a trader. Private or state entities

can apply for trading license. The state governments and the distribution licensees can undertake trading without obtaining a separate license. Transmission utility cannot take up trading.

CERC released a draft regulation on interstate trading license in December and invited comments. Read Prayas submission in this context [[Prayas comments on CERC trading license](#)] Those applying for trading license should have power system expertise, minimum asset base and should pay an annual license fee to CERC. A Trading licensee cannot have transmission business. The CERC issued its order and regulations on inter-state trading in January 2004. These are available at the CERC website.

The major condition for obtaining a trading license is financial strength. The net-worth of the company should be in the range of Rs 2 to 25 Crore for a trading limit of 100 to 1000 MU (or more) per month. The license fee is to be decided by the MoP but is likely to be in the range of Rs 1 to 15 lakh per year.

RCs are expected to fix the trading margins from time to time. There has been lot of interest in power trading and several companies have approached CERC for license. This includes Reliance Energy, Adani Exports Ltd, Essar, Koyela Energy, Tata Power and Amalgamated Transpower.

The CERC has also indicated that it will work on creation of National power exchange to facilitate direct interaction between generator and consumers. But it is expected to be a few years away.

The captive power plants, SEBs having excess power (of their own or from contracts) and merchant power plants are the likely sources for power; while, the large industry and distribution licensees are expected to be the buyers of the power.

7. Consumer Issues

7.1 Grievance Redressal

With the advent of reform, there has been an increased attention to consumer grievances. Earlier some utilities have been conducting public courts (adalats), State reform acts and the ERC Act had provision for a consultative committee with consumer representation. RCs have been organising public hearings on major issues. Karnataka RC supports an Electricity Consumers Network to function as a friendly interface between RC and the consumer. E-Act has many provisions intended to further this.

Every distribution licensee is to establish a forum for redressal of consumer grievances as per the guidelines of the respective RC. The RC is to set up a redressal authority one level higher in the form of an 'Ombudsman'. [42-5,6,7]. As a first step, licensees would generally be required to publish comprehensive document describing their rules and in-house grievance redressal process. If the consumer complaint is not satisfactorily solved by utility, he/she can approach the Forum, with an appeal. And appeal against the decision of forum will lie with the Ombudsman. Hence, now the consumers can approach these specialized courts in addition to the consumer forums. Distribution licensees have the duty to provide power supply to any consumer within one month of receipt of an application, subject to some clauses [43,44]. RC is expected to specify standards of performance for distribution licensee. Performance of the licensee with respect to the performance standards is to be published by the RCs once a year. Fines can be imposed and compensation demanded if these are not met [57,58,60]. Advisory Committees of the RCs at the Central and State levels will have a representation from consumers [80,87].

7.2 Theft

Many states (like AP, West Bengal) had enacted legislations to handle power theft even before the E-Act. E-Act contains stringent provisions to handle power theft. Part 14 and 15 of the Act [sections 135 to 157] describes offences, punishments and the provision of Special courts to handle these. This includes:

- Theft of electricity
- Theft of electric lines and materials
- Receiving stolen property
- Interference with works of the licensee
- Negligent or malicious waste of electricity
- Extinguishing public lamps

The State government and the licensee can authorise an officer to enter, inspect, break open and search any consumer premises to detect theft. They can also seize and remove any relevant devices or documents [135, 163]. Compounding fines (i.e. payment of fine against withdrawal of cases) have been specified. Special courts may be set up by the states for speedy trial of these offences related to power theft.

8. Tariff

Before the advent of the RCs, the respective State governments handled the functions of formulating the tariff guidelines and setting the tariff. In States where RCs are functional, they have taken up the role of tariff setting under the policy guidelines of the respective States. CERC has been setting the tariff for central utilities. E-Act formalises the approach to tariff and procedure for tariff setting.

Sections 61 to 66 of the E-Act address tariff issues. RCs are expected to set the generation, transmission and distribution tariff on 'commercial' lines. The cost of electricity is to be recovered in a 'reasonable' manner. Tariff is to progressively reflect the cost of supply and cross subsidy is to be eliminated within a time period specified by the appropriate RC. Multi-year tariff principles (where tariff is set for a few years ahead) is to be adopted [61]. E-Act requires MoP to prepare a National Electricity and a National Tariff policy which would guide RCs for tariff setting. The National Electricity Policy has been notified in February 2005 and National Tariff Policy in Jan 06.

For tariff revision or determination of the tariff, the licensee is to make an application to the RC. The application can be reviewed by the public and comments submitted to the RC. After reviewing the comments, RC would pass the tariff order. The RC is mandated to pass the order within 120 days of accepting the tariff application. Although E-Act does not explicitly mention the need of a public hearing before deciding on tariff, it is now a well-laid precedence to have public hearings. Typically tariff is expected to be set once a year.

In case of multiple distribution licensees in the same area, RC would set the ceiling on tariff. For traders, the trade margins are to be decided by RC. In case of competitively bid projects (generation or transmission), the resultant tariff shall be accepted by RC.

In July 2003, Ministry of Power released a draft National Tariff Policy and comments were invited. With clear guidelines on issues like availability based incentives, Time of the Day tariff, depreciation calculations etc, many felt that this draft reduced the flexibility of RCs. This policy is available at the MoP website. [See [Prayas comments on 1st draft National Tariff Policy](#)]. Later, the GoI announced setting up of a high powered Task Force (TF) to advise it on a range of issues including the tariff policy, and effectively withdrew its Tariff Policy. [See [Prayas Presentation to the TF](#), Prayas Letters to highlight some key issues. [Letter dated 25th Dec 2003](#),]. The Taskforce report was finalised in February 2004 and this includes Tariff policy. Subsequently, another

Tariff Policy draft was issued in March 2005. [See Prayas Comments on Tariff Policy]. The final National Tariff Policy was issued in January 2006.

The E-Act expects RCs to align tariff to the cost of supply. If this is done, the tariff for the HT industry will reduce substantially – the cost of long LT network will not be charged to these customers. Moreover, HT industry generally have flatter load curve hence demand less of costly peaking power. While, the tariff for LT users, especially the residential and the rural consumers would increase. The residential consumption is predominantly at the peak time and costs more to provide, and the rural consumers need large extension of network. For the agricultural consumers, the tariff would be below the average cost of supply, as these consumers are the first to be cut off in case of load shedding. The utility can use the cross-subsidy cess in the transition period to support the cross-subsidy. In the long run, the government will have to shell out money from the budget to keep tariffs low of the poor consumers, or assign the historical low-cost generating stations for the poor.

9. Institutions and Policy

9.1 Increasing role of Central Government

Power has been, and continues to be in the concurrent list of the constitution. Central and State governments have specified roles in policy making and operating the sector. Country-wide planning, funding, fuel issues, crucial manufacturing, bulk generation, research and inter-state transmission have been handled by the Central government. States managed the planning and operation of the state power grids. With the poor performance of the State utilities, the role of the Central government in the sector has been slowly increasing. E-Act is a culmination of this change. Another reason for increased role of the central government has been, the need for a uniform policy across the country to ensure level playing field essential to facilitate competition.

9.2 Electricity: from a development input to commodity

For many years after independence, electricity was looked upon as a major development input. With this view, governments gave emphasis to rural electrification and energising agricultural pumpsets. Along with this, the policy of cross subsidy, where the industry and commercial consumers subsidised the electricity to the small domestic and agricultural consumers was consciously followed. ERC Act suggests time bound plan to remove cross subsidy but this was not taking place as desired. The E-Act, allows large industry to quit the grid and converts cross-subsidy removal policy into economic imperative. It also encourages numerous agencies to take up rural electrification.

9.3 Reducing role of CEA and Centralised planning

Subsequent to the E-Act, the role of CEA has substantially reduced. From a small body of 7 members (6 permanent and 1 part-time), it has been expanded to have 'not more than 14 members'. Of which, 8 would be full-time members and rest part time. Any member can be removed by the Central government, without giving reasons [70]. The responsibility of Techno-Economic Clearance (TEC) for generation projects have been removed from the CEA, except for hydro-electric stations [7,8]. TEC by the CEA was one tool to ensure technological and economic rationality of generation investments in the country, which will now be replaced by forces of competition and market.

As per the provisions of the E-Act, CEA will advise the government (central, state or RCs) on national electricity policy, standards of performance and other technical matters. It would promote research in the sector and publish periodic reports. Every licensee, generating company and even captive plant are expected to provide the required information to the CEA for preparing

regular reports [73,74]. This can be a powerful tool to partially mitigate the information asymmetry present between different stakeholders in the sector.

9.4 End of the road for SEBs

SEBs are expected to be re-organised and converted into corporations in less than one year after the E-Act is notified [131,172]. During the transition period, the SEB would be deemed as a transmission utility and can be subsequently unbundled. Deadline for SEB's to unbundled was June 2004, as per the E-Act. This was extended to June 2005 and subsequently for 6 more months. As of June 2005, 13 SEBs have been unbundled.

For coordinated operation of the sector, Central government is to constitute a coordination forum consisting of CERC members, Chairperson-CEA, and representatives of generating and transmission licensees engaged in interstate operation. Central Government will also constitute a forum of regulators consisting of Chairperson – CERC and Chairpersons of State RCs. Similar forums are to be formed at State and District levels. [166].

9.5 National Electricity Policy

The National Electricity Policy was notified on February 12, 2005. The policy continues with the spirit of competition, privatisation and supply orientation, as in the E-Act and previous draft policies. Emphasis on rural access, qualifiers on energy efficiency, statements on relief & rehabilitation are some welcome points of departure. Some key features of the policy are capacity expansion to meet the power demand by 2012, providing access to electricity for all households in next five years, per capita availability of electricity to be increased to over 1000 units by 2012, and minimum lifeline consumption of 1 unit/household/day as a merit good by year 2012, lifeline tariff (upto 50% of average cost of supply) to consumers with less than 30 units/month, keeping 15% generation capacity outside long term PPAs etc. It also clarifies that for grant of second distribution license, a revenue district, a Municipal Council or a small urban area will be the minimum area.

| Function | Before E-Act | After E-Act | Remarks |
|--------------|----------------|--------------------------------------|--------------------------------------|
| Generation | State, Private | Increasing Private | Liberal licensing and Captive policy |
| Transmission | State owned | State and Private owned corporations | |

| | | | |
|------------------|--------------------------------------------------|------------------------------------------------------------------------------------------------------------------------------------|------------------------|
| Distribution | State, Private | Corporations - increasingly Private (especially in urban areas), Multiple licensees, Standalone systems in rural | |
| Regulation | State, RC | State, RC and ATE | ATE is the addition |
| Trading | Mostly bi- lateral, PTC the only player | Market based, many licensees | |
| Policy making | Governme nts at Centre and State | Increased role of Central government | |

10. Major Policy Initiatives

E-Act expects formulation of several major policies within a time frame of about a year. Different agencies have the responsibility of drafting these, consolidating comments, and finalising these policies. Table below gives a summary of major policies. Typically few weeks are given to public for giving comments on these draft policies. Right now, the Central policies are getting finalised and then the States would follow these or in some cases, prepare their own guidelines in accordance with central policies.

The draft policies / guidelines are made available at websites of MoP, CERC, or the respective state RCs. In most cases, inviting public comments is mandatory and in some cases public hearings are also held before finalising the policies.

| Policies after E-Act 2003 | | |
|-----------------------------------|----------------------------------------------------------------------------------------------------------------------------------------------------------------|----------------------------------------------------------------------------------------------------------------------------------------------------------------------------------------------------------------|
| Name | Release date | Remarks |
| National Tariff policy | Discussion paper in July 2003, Drafts in Feb 04, Aug 04, March 05. Final in Jan 06 | Discussion paper prepared by MoP with support from CRISIL. Later drafts by MoP. Available at www.powermin.nic.in . See Prayas comments . |
| National Electricity Policy | February 2005 | Available at MoP site. |
| National Electricity Plan | By CEA in consultation with licensees, public and State/Central governments once in 5 years [3] Draft prepared by CEA in February 2005 | Available at CEA site. See Prayas Comments. |
| Task Force on | Aug 2003 | 5- member team headed by Mr. N |

| | | |
|--------------------------------------------------|----------------------------------------------------|--------------------------------------------------------------------------------------------------------------------------------------------------------------------------------------------------------------------|
| Power sector investments and reforms | | K Singh (Planning Commission) to review all policies. Terms of reference available at MoP website. <u>Prayas presentation</u> , <u>Prayas letter to the Chairperson of TF</u> . Report submitted in February 2004. |
| Open Access in inter-state transmission | Final Order and Regulations in January 2004 | Prepared by CERC staff, available at CERC site. <u>See Prayas comments</u> |
| Open access – intra-state | State level regulations getting finalised | As of Nov 05, 11 states have prepared regulations. |
| Trading - Inter-state | Order in Jan 2004 | Available at CERC Site. <u>Prayas Comments</u> available at website. |
| Trading – Intra-State | State level regulations getting finalised | As of Nov 05, few states have finalised regulations. |
| Rural Electrification Policy | Discussion paper in Nov 2003, Policy not announced | Prepared by MoP and available at MoP site. <u>See Prayas note</u> introducing the discussion paper. |
| Conduct of Business Regulations | Prepared by most SERCs | By State and Central RCs. Public comments are mandatory. CBR are the key regulations for operationalising transparency of RCs. |
| Performance standards for Distribution licensees | Prepared by many SERCs | By State RCs. 11 States have prepared regulations by June 2005. |

11. Alerts

1. CMP of the UPA government has committed to review the E-Act. This process is still not complete. Areas include the power of the regulators versus the government, removing cross subsidy, rural electrification, re-organisation of SEBs etc.
2. Discussions on market structure in progress.
3. State RCs are finalising regulations on issues like consumer grievance, open access, standard of performance, trading etc.

12. Annexure

Important Links

Prayas, Pune www.prayaspune.org
Ministry of Power <http://powermin.nic.in>
Central Electricity Authority <http://www.cea.nic.in>
National Thermal Power Corporation www.ntpc.co.in
Powergrid Corporation of India www.powergridindia.com

Regulatory commissions

- 1 Assam Electricity Regulatory Commission aerc.nic.in
- 2 Andhra Pradesh Electricity Regulatory Commission ercap.org
- 3 Central Electricity Regulatory Commission cercind.org
- 4 Delhi Electricity Regulatory Commission dercind.org
- 5 Gujarat Electricity Regulatory Commission gercin.org
- 6 Himachal Pradesh Electricity Regulatory Commission hperc.nic.in
- 7 Haryana Electricity Regulatory Commission herc.nic.in
- 8 Karnataka Electricity Regulatory Commission kerc.org
- 9 Madhya Pradesh Electricity Regulatory Commission mperc.org
- 10 Maharashtra Electricity Regulatory Commission mercindia.com
- 11 Orissa Electricity Regulatory Commission orierc.org
- 12 Rajasthan Electricity Regulatory Commission rerc.gov.in
- 13 Tamil Nadu Electricity Regulatory Commission tnerc.tn.nic.in
- 14 Uttaranchal Electricity Regulatory Commission uerc.org
- 15 Uttar Pradesh Electricity Regulatory Commission uperc.org
- 16 West Bengal Electricity Regulatory Commission wberc.net

GLOSSARY OF TERMS

| | |
|-----------------|-----------------------------------------------------------------------------------------|
| ABT | Availability Based Tariff |
| ADB | Asian Development Bank |
| APDRP | Accelerated Power Development Programme |
| ARR | Annual Revenue Requirement |
| ATE | Appellate Tribunal for Electricity |
| BSES | Bombay Suburban Electric Supply Company (renamed as REL in 2003) |
| BST | Bulk Supply Tariff |
| CCGT | Combined Cycle Gas Turbine (based power plant) |
| CEA | Central Electricity Authority |
| CERC | Central Electricity Regulatory Commission |
| CPP | Captive Power Project |
| CPTC | Central Power Trading Corporation |
| CRISIL | Credit Rating Information Service of India Limited |
| CSIs | Civil Society Institutions |
| CTU | Central Transmission Utility |
| DFID | Department for International Development (of UK, called ODA before) |
| DISTCOM/ DISCOM | Distribution Company |
| DSM | Demand Side Management |
| E-Act | Electricity Act 2003 |
| EHV | Extra High Voltage |
| ERC Act | Electricity Regulatory Commissions Act (1998) |
| Financial Year | Indian Financial Year - 1st April to 31st March. Typically represented as FY 98-99 etc. |
| GENCO | Generation Company |
| GoI | Government of India |
| GRIDCO | Grid Corporation |
| HP | Horse Power (1 HP = 746 Watts) |
| HT | High Tension (or High Voltage) |
| HVDC | High Voltage Direct Current |
| Hz | Hertz |
| ICRA | Investment information and Credit Rating Agency of India |
| IDBI | Industrial Development Bank of India |

| | |
|-----------------|-------------------------------------------------------------------------------|
| IDFC | Infrastructure Development Finance Company Ltd |
| IPPs | Independent (Private) Power Producers |
| IPs | Irrigation Pump Sets |
| IRP | Integrated Resource Plan (usually implying a least-cost plan that takes an |
| integrated view | toward all energy options) |
| kCal | Kilo Calories |
| kg | Kilograms |
| kV | kilo Volt |
| kVA | kilo Volt Ampere |
| kW | kilo Watt |
| kWh | kilo Watt hour |
| LNG | Liquefied Natural Gas |
| LT | Low Tension (or Low Voltage) |
| MDBs | Multilateral Development Banks (such as the WB and ADB) |
| MkCal | Million kilo Calories |
| MoP | Ministry of Power |
| MoU | Memoranda of Understanding |
| MU | Million Units (million kWh) |
| MW | Mega Watts |
| NCAER | National Council for Applied Economic Research |
| NGOs | Non-Government Organisations |
| NHPC | National Hydro Power Corporation |
| NLDC | National Load Dispatch Centre |
| NPC | Nuclear Power Corporation |
| NTPC | National Thermal Power Corporation |
| ODA | Overseas Development Agency, UK (now called DFID) |
| OEFC | Overseas Economic Corporation Fund of Japan |
| ONGC | Oil and Natural Gas Corporation |
| O&M | Operation & Maintenance |
| PFC | Power Finance Corporation (a GoI-owned financing agency for the power sector) |
| PLF | Plant Load Factor (also called Capacity Utilisation Factor) |
| POWERGRID | Powergrid Corporation of India Limited (the CTU) |
| R&M | Repair & Maintenance |
| RBI | Reserve Bank of India |
| REB | Regional Electricity Board |
| RC | Regulatory Commission |
| REC | Rural Electrification Corporation, New Delhi |
| REL | Reliance Energy Limited (formerly BSES) |
| RLDC | Regional Load Dispatch Centre |
| Rs | Rupees |
| RST | Retail Supply Tariff |
| SEBs | State Electricity Boards (vertical monopoly power utility owned by the state |
| government) | |
| SERC | State Electricity Regulatory Commission |
| SLDC | State Load Dispatch Centre |
| STU | State Transmission Utility |
| T&D | Transmission and Distribution |
| TEC | Techno Economic Clearance |
| TOD | Time-Of-Day |
| TPC | Tata Power Company |
| TRANSCO | Transmission Corporation |
| WB | The World Bank group |

